

Control valves
Series 1000
 Valve 2 way flanges



KLINGER ITALY SRL - Viale Alcide De Gasperi, 88—20017 RHO (MI) ITALY

klinger@klinger.it — www.klinger.it

Tel.: +39 02 933331

Technical data

Size (DN)	DN 15 - 100 (1/2" - 4")
Pressure rating	PN16
Connections	Flanges UNI/DIN PN16 Welding BW
Type sealing	Soft (Class VI)
Characteristic	Equalpercentage (eqp%)
Action	Pneumatic with diaphragm (supply max 3 bar)
Temperature	from -30 to +200° C

Description

Pneumatic 2 way valves at free-flow with high coefficient of flow, solid construction and compact. All Burocco valves are delivered after testing and calibration and ready for a long utilize, without maintenance.



Options

- ⇒ Plug sealing HPP PEEK
- ⇒ Characteristic linear
- ⇒ Flanges can be drilled to ANSI 150 but with face to face and rating according to DIN
- ⇒ Handwheel for emergency operation
- ⇒ Valve positioners
- ⇒ Limit switches
- ⇒ Airset

Materials

Valve body	316L
Trim (plug - seat)	316L + PTFE, PTFE-CG or PEEK plug insert
Stem	316L
Packing	PTFE, PTFE+'OR' FPM
Body gasket	PTFE
Actuator	FE (epoxy varnish) Stainless steel
Yoke	Stainless steel



Control valves
Series 1000
 Valve 2 way flanges

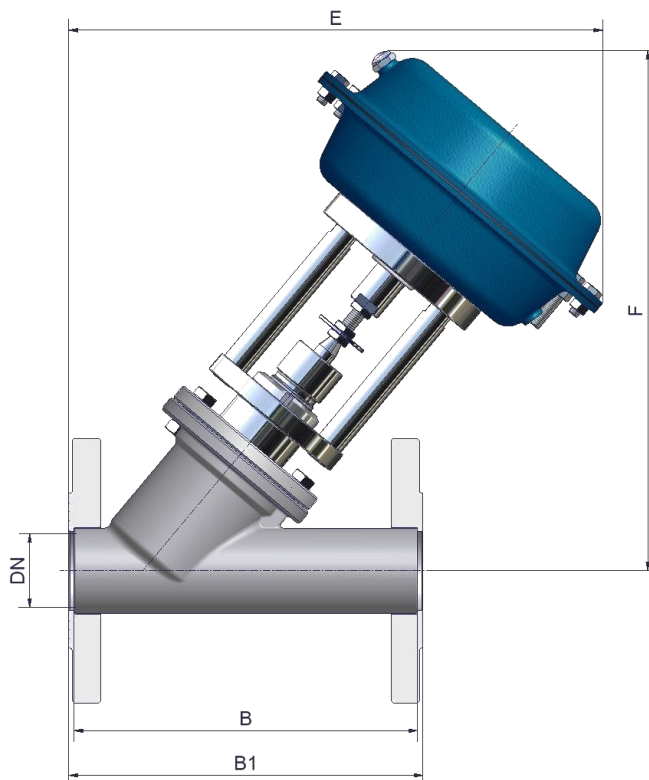

KLINGER ITALY SRL - Viale Alcide De Gasperi, 88—20017 RHO (MI) ITALY

klinger@klinger.it — www.klinger.it

Tel.: +39 02 933331

Dimensions (mm)							Weight (kg) *							
DN	CV	Kvs	Thread	B (BW)	B ₁ (Flanges)	E		F		BW	BW	Flanges	Flanges	
						Actuator	∅200	∅275	∅200	∅275	∅200	∅275	∅200	∅275
8	2	1,7	1/4"-3/8"	126		270		242		5.5		5.7		
11	3	2,5	1/4"-3/8"	126		270		242		5.5	---	5.7	---	
15	5	4,3	1/2"	126	130	267	288	253	274	5.7	10.2	6.6	11.1	
20	9	7,7	3/4"	146	150	283	304	263	284	5.8	10.3	7.3	11.8	
25	14	12	1"	156	160	283	304	264	285	5.9	10.4	8.3	12.8	
32	22	18,8	1"1/4	176	180	281	307	274	300	6.4	10.9	9.8	14.3	
40	34	29	1"1/2	196	200	300	326	291	312	7.4	11.9	11.3	15.8	
						Actuator	∅275	∅340	∅275	∅340	∅275	∅340	∅275	∅340
50	53	45,3	2"	226	230	342	376	325	366	12.9	18.9	16.9	22.9	
						Actuator	∅340	∅430	∅340	∅430	∅340	∅430	∅340	∅430
65	91	77,8	2"1/2	286	290	464	505	426	458	23.8	29.8	30.5	36.5	
80	138	118	3"	306	310	479	520	450	482	27.4	33.4	34.1	40.1	
100	217	185,5	4"	345	350	513	554	464	496	31.5	37.5	40	46	

* without positioner, airset or other accessories

Control valves

Series 1000

Valve 2 way flanges



KLINGER ITALY SRL - Viale Alcide De Gasperi, 88—20017 RHO (MI) ITALY

klinger@klinger.it — www.klinger.it

Tel.: +39 02 933331

Technical data

Size (DN)	DN 10 - 50 (1/4" - 2")
Pressure rating	PN25
Connections	Welded SW Female threaded GAS 1/4" - 2"
Type sealing	Soft (Class VI)
Characteristic	Equalpercentage (eqp%)
Action	Pneumatic with diaphragm (supply max 3 bar)
Temperature	from -30 to +200° C

Description

Pneumatic 2 way valves at free-flow with high coefficient of flow, solid construction and compact. All Burocco valves are delivered as tested units and ready for a long lasting, maintenance free operation.

Options

- ⇒ Plug sealing HPP PEEK
- ⇒ Characteristic linear
- ⇒ Handwheel for emergency operation
- ⇒ Valve positioners
- ⇒ Limit switches
- ⇒ Airset



Materials

Valve body	316L
Trim (plug - seat)	316L + PTFE, PTFE-CG or PEEK plug insert
Stem	316L
Packing	PTFE, PTFE+'OR' FPM
Body gasket	PTFE
Actuator	FE (epoxy varnish) Stainless steel
Yoke	Stainless steel

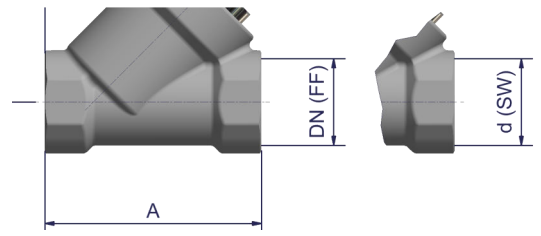

KLINGER reserves the right to make improvements without prior notice 12/16

Control valves
Series 1000
 Valve 2 way flanges

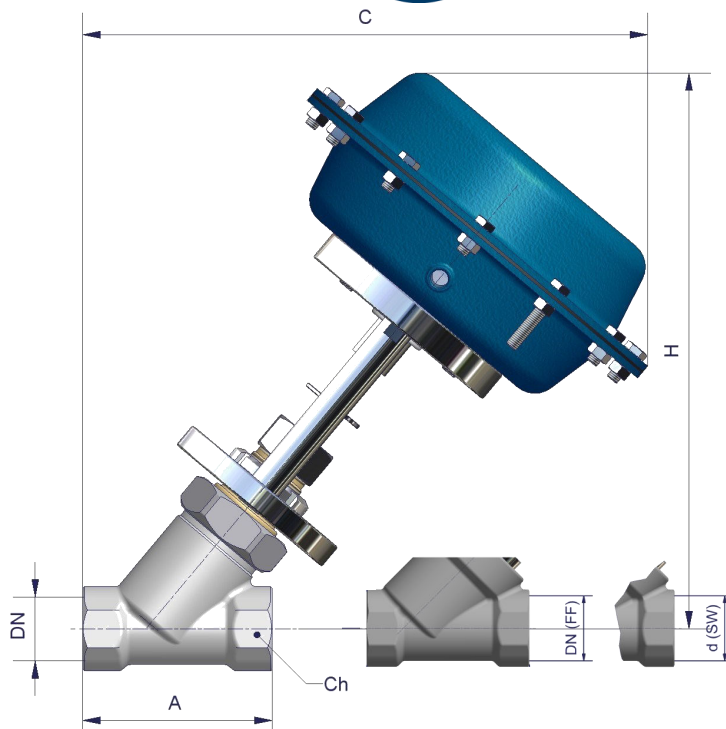

KLINGER ITALY SRL - Viale Alcide De Gasperi, 88—20017 RHO (MI) ITALY

klinger@klinger.it — www.klinger.it

Tel.: +39 02 933331

Dimensions (mm)							Weight (kg) *					
DN	CV	Kvs	Thread	A	Ch	C	H		FF/SW			
				(FF/SW)	(FF/SW)							
						Actuator	Ø200	Ø275	Ø200	Ø275	Ø200	Ø275
8	2	1.7	1/4"-3/8"	60	22	267		242		5		
11	3	2,5	1/4"-3/8"	60	22	267		242		5.4	---	
15	5	4,3	1/2"	65	27	275	296	248	269	5.6	10.1	
20	9	7,7	3/4"	75	32	278	299	250	271	5.7	10.2	
25	14	12	1"	90	39	274	295	264	285	5.9	10.4	
32	20	17,1	1"1/4	110	50	290	316	266	292	6.2	10.7	
40	32	27,4	1"1/2	120	55	300	326	278	299	7	11.5	
						Actuator	Ø275	Ø340	Ø275	Ø340	Ø275	Ø340
50	50	42,8	2"	150	68	346	380	308	349	12.3	18.3	

* without positioner, airset or other accessories